

PAT-Drill 421

Trailer Mounted Drilling Rig

The PAT-Drill 421 is a heavy duty version of the compact trailer mounted rig. With a heavier and stronger mast, chassis and power pack it provides an alternate machine – ideally suited to being towed by light truck or Land Cruiser.



Key Features :

3000 Kg. capacity Single Axle - With Heavy Duty “split ring” all steel wheels.

Rotary Head - 50 mm (2”) Air/Water pipe work & flanged drill pipe adaptor.

Flush drill pipe 76 mm diameter or ‘open throat’ 90 mm diameter for efficient deep mud drilling.

4 Heavy duty hoist points to facilitate crane truck loading.

Re-positionable levelling jacks giving high ground clearance or vehicle mounting options.

Optional 1,000 Kg. mast head winch for 3 m casing handling.

TECHNICAL DATA & SPECIFICATION

RECOMMENDED HOLE RANGE (Depths to 180 m)

Medium & Hard rock, DTH-Hammer drilling :

(Needs a separate air compressor)

3" - 5" DTH-Hammer with the capacity to drill

4" - 6 1/2" (100-165 mm) diameter.

Soft formations, rotary 'mud' drilling :

(Needs a separate mud pump)

Drag bit 4" - 12" (100-305 mm) diameter.

TOP ROTATION HEAD

Single reduction gearbox, hydraulic motor driven, and variable rotation speed. Enable to swing-a-side for easily casing installation.

50 mm (2") Air/water pipe work & flanged drill pipe adaptor inside diameter, sub joint 2 3/8 API Reg Mod

Gear box ratio: 4.75 : 1

Speed: 0 - 65 rpm

Max. torque: 2,660 Nm

MAST

All steel work, 3.50 metres high, break-out table to open 305 mm diameter. Mast raised to vertical from storage position by a hydraulic cylinder through heavy duty chain. The mast is also equipped with 2 LED flood lights for night time operation.

FEED SYSTEM

Rotation head is raised and lowered by a hydraulic cylinder and heavy-duty transmission chain. Head travelling stroke 2.25 metres

Pull up - Capacity: 4,900 kg

Max. speed: 15.00 metres/min

CONTROL PANEL

4 levers controlling rotation head, pull and feed

2 regulators for rotation speed and pull/feed weight

4 system pressure gauges

Rigid mounted control panel with lockable cover plate.

HYDRAULIC POWER PACK

Engine: 47 hp (35.0 kW) at 3000 rpm, 4 cylinders, YANMAR 4TNV88-DSA diesel engine, water-cooled, electric start.

Hydraulic system: Triple gear pump type, system pressure 250 bar max, 130 litres tank capacity.

Fuel tank: 27 litres

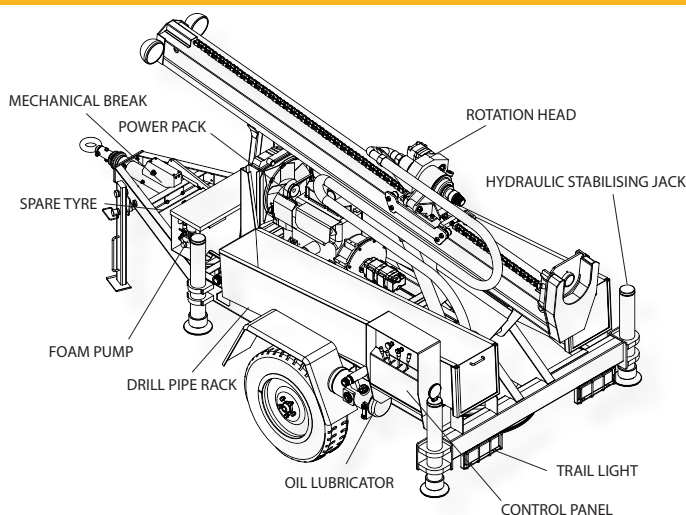

WATER/FOAM INJECTION PUMP

Triple piston pump driven by a hydraulic motor.

Motor speed: 450 rpm

Max. displacement: 10 litres/min

Max. working pressure: 30 bar

STABILISING JACK

4 jacks hydraulic, re-positional to adjust ground clearance.

AIR LUBRICATION SYSTEM

Fitted lubricator of Venturi-type for inject lubrication-fully adjustable flow control-for DTH-Hammer

Max pressure 40 bar

Oil tank capacity 7 litres

PIPE RACK

Each side containing: (For 2 metre) 20 pcs. 76mm pipe

DRILL PIPE

Drill pipe length: 2 metres

Drill pipe diameter options: 60, 76 & 90 mm

TRAILER

Heavy duty prop leg. 4 Heavy duty hoist points to facilitate truck loading.

Towing: Ring OD = 120 mm, ID = 70 mm
Thickness = 25 mm

Brake system: mechanical break for overrun parking and auto reverse.

Suspension: Single axle, torsion sprung with overrun brake system. 3000 kg capacity.

Trailer light: Fitted trailer lights with 7 pin plug connection to vehicle system.

Wheels & Tyres: 8.25-R16, 14 PLY 2 + 1 spare with inner tubes. Heavy duty all steel "split ring" wheel truck style.

* Optional 1,000 kg mast head winch for 3 m casing handling.

DIMENSIONS

Overall length : (L) 4.14 m

Overall width : 1.82 m

Overall height : (H) 2.0 m

Weight (without drill pipes) 2,160 kg

Promotion of Appropriate Technology Co.,Ltd. reserves the right to change these specifications without notice



PROMOTION OF APPROPRIATE TECHNOLOGY CO.,LTD

44 Moo 4 CHIANGRAK NOI, SAMKOK PATHUMTHANI 12160 THAILAND

Phone +66(0)2199 3785-6 Fax+66(0)2199 3787 www.pat-drill.com Email: pat@pat-drill.com