

PAT-Drill 501

Part no 50 1 0000

Drilling Rig Mounted on Trailer

PAT-Drill 501 is a drilling rig mounted on tandem trailer. Robust with full hydraulic service, DTH-Hammer rotary drilling rig, ideal for deeper and more challenging water wells.

- An independent deck engine on board.
- High torque rotation head with dual hydraulic motors.
- Advantage, fast drilling with 3 metre Drill pipe, storage moves from transport to vertical to aid handling.
- All service functions well arranged on easily operated control panel

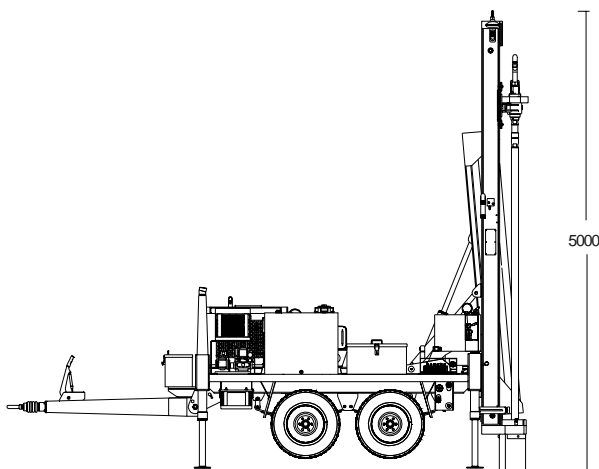

The PAT-Drill Rigs are popular choice for Government, United Nations, and Non-Government organizations (NGO) looking for appropriate and low cost drilling equipment to provide domestic water supplies to rural village communities at an economical price.

Technical Data, Specifications

TOP HEAD ROTATION

Single reduction gearbox, 2 hydraulic motors, variable rotation speed.
Ability swing-a-side for easy casing installation.
Swivel spindle 40 mm inside diameter, sub joint 2 3/8 API Reg Mod

Gear box ratio	4.75 :1
Max. torque	4840 Nm
Speed	0 - 50 rpm

FEED SYSTEM

Rotation head raised and lowered by a hydraulic cylinder through heavy-duty transmission chain.

Head travelling stroke:	3.25 metres
Pull-up	
Capacity	4350 kg
Max. speed	25.5 metres/min
Pull-down	
Capacity	2900 kg
Max. speed	38.5 metres/min

DRILL PIPE

Drill pipe length	3 metres
Drill pipe OD	76 mm
Thread	2 3/8 API Reg Mod

WATER/FOAM INJECTION PUMP

Triplex piston pump driven by an hydraulic motor.

Motor speed	450 rpm
Max. displacement	10 litres/min
Max. working pressure	30 bar

HYDRAULIC POWER SYSTEM

Powered by deck engine, YANMAR diesel, 4 cylinders, with turbocharger 52 hp (38.8 Kw) at 2800 rpm, water-cooled, electric start, coupled to hydraulic pumps. The hydraulic system with oil-cooling and 10-micron filtration.

System pressure	250 bar max.
Hydraulic tank capacity	125 litres
Oil cooling system	4100-5300 Kcal/hr at 40 C
Fuel tank	40 litres

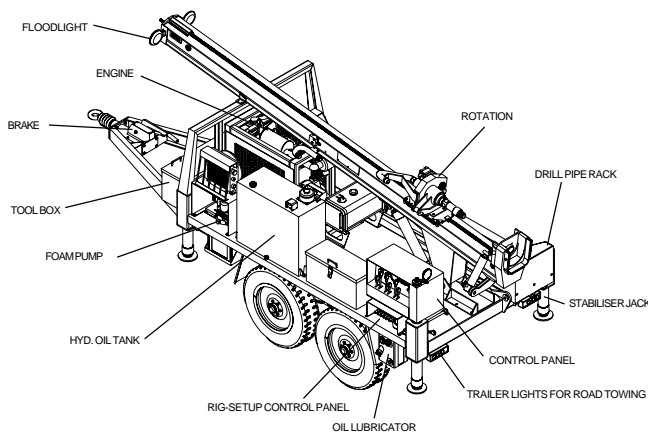

STABILISING JACK

2 front and 2 rear jacks

Bore	80 mm
Stroke	500 mm
Max. load push-up	6150 kg per jack

HYDRAULIC BREAK-OUT WRENCH

Break-out torque	7770 Nm
------------------	---------

AIR LUBRICATION SYSTEM

Fitted lubricator of Venturi-type for adjustable drip feed to DTH-Hammer

Max. pressure	40 bar
Oil tank capacity	8.5 litres

PIPE RACK

Containing	24 pieces
------------	-----------

LIGHTING & ELECTRICAL SYSTEM 12 Volt DC

Mast	2 x 55 watt flooding lights
Control panel	1 floodlight and 2 background lights

TRAILER

Towing	Standard towing eye
Brake system	mechanical for overrun, auto-reversing and parking
Suspension	4 leaf springs and 4 shock absorbers
Trailer light	Fitted trailer lights with 7 pin plug connection to vehicle system
Tyres	750-R15, 12 PLY

WEIGHT : 3080 kg (without drill pipes)

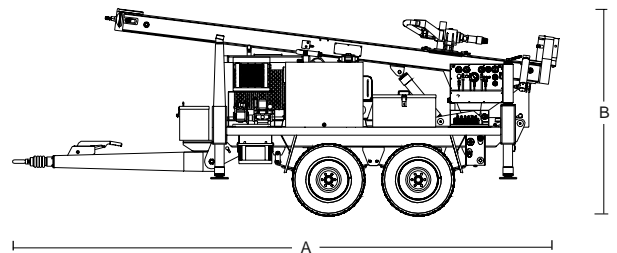

DIMENSIONS

Overall length (A)	5643 mm
Overall width	1790 mm
Overall height (B)	2155 mm