

# PAT-Drill 401T

## Drilling Rig mounted on Trailer

The PAT-Drill 401T is a Trailer mounted drilling rig, compact fully hydraulic, for down-the-hole hammer and rotary drilling up to 200 meters.

An independent deck engine mounted on board the heavy-duty tandem axle 4 wheel.

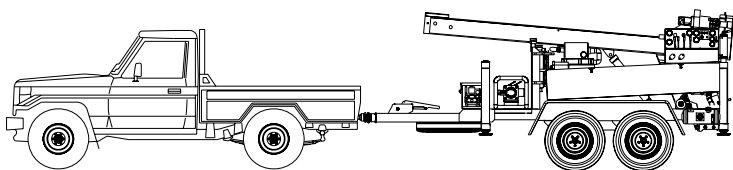

Toyota LandCruiser & 401T Basic Rig

*The PAT-Drill 401 T is the right choice for Government, United Nations, and Non-Governmental (NGO) organizations looking for appropriate and low cost drilling equipment to provide domestic water supplies to rural village communities at an economical price.*

# PAT-Drill 401T

## Technical Data, Specifications

### TOP HEAD ROTATION

Single reduction gearbox with a hydraulic motor.  
The system provides infinitely variable rotation speed.  
Main shaft of 40 mm. hole, Sub joint 2 3/8 REG API Mod.  
Enable to open "Swing-a-side", for putting the casing.

Rotation torque	2232 N-m
Speed	0 - 34 rpm.

### FEED SYSTEM

Top head drive by a hydraulic cylinder through heavy duty chain.

Head travel	2.25 meter
Pull-up capacity	3813.09 kg.
Pull-up speed-slow feed	1.22 meter/min
Pull-up speed-rapid feed	12.26 meter/min
Pull-down speed-slow feed	0-1.88 meter/min
Pull-down speed-rapid feed	0- 16.90 meter/min

### DRILL PIPE

Drill pipe length	2.00 meter
Drill pipe diameter	76 mm.
Thread	2 3/8 REG API Mod.

### WATER-FOAM INJECTION PUMP

Triplex piston pump driven by hydraulic motor.

Motor speed	365 rpm.
Displacement	10 liter/min
Max working pressure	30 bar

### POWER

Powered by deck engine, "YANMAR" diesel engine  
4 cylinders, 47 hp. at 3000 rpm, water cooled.

Power pack speed	3000 rpm.
Load power pack max.	47 hp.

### HYDRAULIC SYSTEM

3 pumps open system with 10 micron filtration and breather with oil cooling system.

Hydraulic tank capacity	140 liter
-------------------------	-----------

### STABILIZING JACK

2 front jacks and 2 rear jacks.

Bore	80 mm.
Stroke	480 mm

### HYDRAULIC BREAK-OUT WRENCH

Break-out torque	792.22 kg-m.
------------------	--------------

### AIR SYSTEM

Lubricator of venturi-type for down-the-hole drills.

Max. pressure	40 bar
Oil tank capacity	8 liter

### LIGHTING & ELECTRICAL SYSTEM 12V.DC

Mast	2 w. Flood lights
------	-------------------

### TRAILER SUSPENSION

Tandem axle torsion on suspension with overrun brake

### MOBILE PROGRESSIVE CAVITY MUD PUMP

Pump is directly coupled to a hydraulic motor through flexible hydraulic hoses coupling.

Flow capacity	400 liter/min
Max. working pressure	6 bar

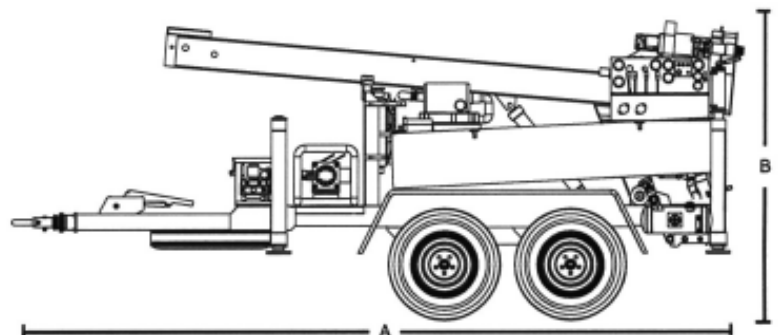
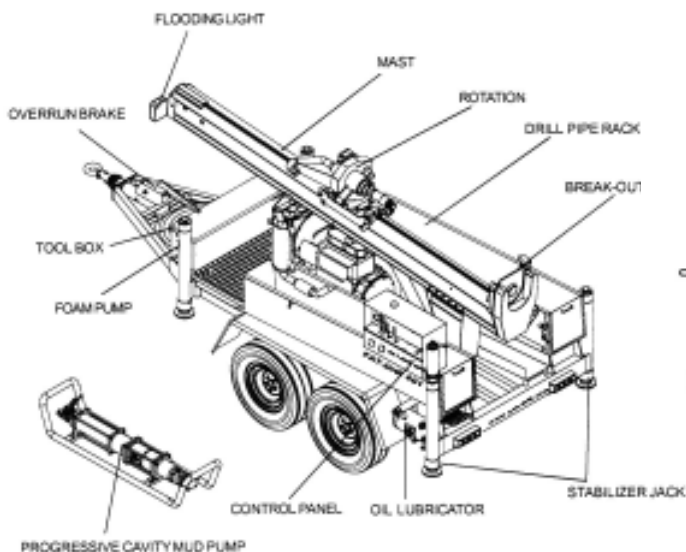

### DIMENSIONS

Overall length (A) :	4540 mm.
Overall width	1750 mm.
Overall height (B) :	1900 mm.